

6 NR 2 PL 8Ω

Professional

6" | 400 W

Code **Z004068**

- 2" voice coil Fiberglass former and Aluminium Winding
- **PS** Spider with Progressive Waves
- **DAR** Rubber surround with Double Asymmetric Rolls Technology (DAR)
- **WpT** Waterproof Cone Treatment
- Neodymium Magnet Circuit
- **VMVc** Ventilated Magnet and Voice Coil to reduce Power Compression
- 91.3 dB sensitivity
- Frequency Range 60-5000 Hz

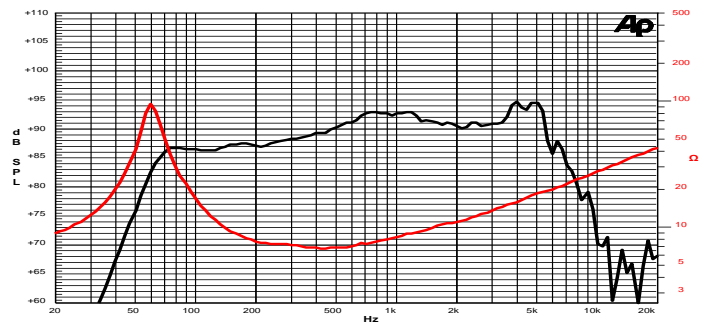
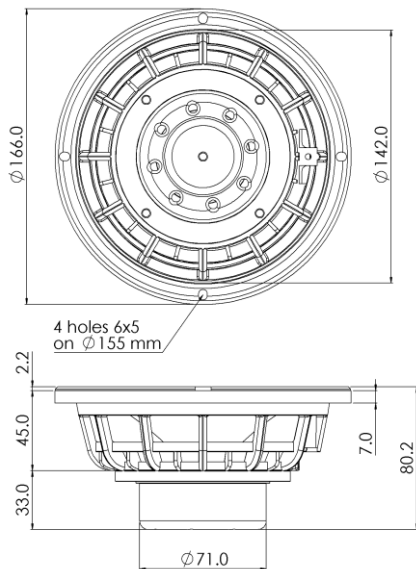

Frequency Response on 18 Lt @ 70 Hz Vented Box @ 1W, 1m
Free Air Impedance

General Specifications

Nominal Diameter	166 mm (6")
Nominal Impedance	8 Ω
Rated Power AES ⁽¹⁾	200 W
Continuous Program Power ⁽²⁾	400 W
Sensitivity @ 1W/1m ⁽³⁾	91.3 dB
Voice Coil Diameter	50 mm (2")
Voice Coil Winding Depth	16 mm
Magnetic Gap Depth	8 mm
Flux Density	1.20 T
Magnet Weight	160 g
Net Weight	1.2 kg

Thiele & Small Parameters ⁽⁴⁾

R_e	5.5 Ω	F_s	62.0 Hz
Q_{ms}	6.28	Q_{es}	0.36
Q_{ts}	0.34	M_{ms}	16.2 g
C_{ms}	407 μm/N	B_{xl}	9.88 Tm
V_{as}	8.7 l	S_d	122.7 cm ²
$X_{max}^{(5)}$	+/-5.0 mm	$X_{var}^{(6)}$	+/-7.5 mm
η_0	0.56 %	L_e (1kHz)	0.56 mH

Constructive Characteristics

Magnet	Neodymium
Basket Material	Aluminium Die-Cast
Voice Coil Winding Material	Aluminium
Voice Coil Former Material	Fiberglass
Cone Material	Paper
Cone Treatment	Surface Waterproof Treatment
Surround Material	Rubber
Dust Dome Material	Solid Paper

Mounting Information

Overall Diameter	166 mm
Baffle Cutout Diameter	143 mm
Mounting Holes	4 holes 5x6 on 155 mm
Total Depth	80.2 mm

⁽¹⁾ Rated Power measured with 2-hour test with pink noise signal, 6dB crest factor, loudspeaker in free air, power calculated on rated Zmin. ⁽²⁾ Power on Continuous Program is defined as 3dB greater than the Rated Power. ⁽³⁾ Calculated by Thiele & Small parameters, for SPL average in box refer to frequency response. ⁽⁴⁾ Thiele & Small parameters measured with laser system after preconditioning test. ⁽⁵⁾ Measured with respect to a THD of 10%. ⁽⁶⁾ Value corresponding to a decay of the Force Factor, or Compliance, or both, equal to the 50% of the small signal value. ⁽⁷⁾ Drawing dimensions: mm.